

# TCK系列数控车床

## 目 次

1	共用电路.....	1-1
2	CNC 电路.....	2-1
3	主轴电路.....	3-1
4	伺服轴电路.....	4-1
5	刀架电路.....	5-1
6	卡盘电路.....	6-1
7	台尾电路.....	7-1
7.1	台尾套筒.....	7-1
7.2	台尾体.....	7-3
8	自动门电路.....	8-1
9	备 注.....	9-1

# 1 共用电路

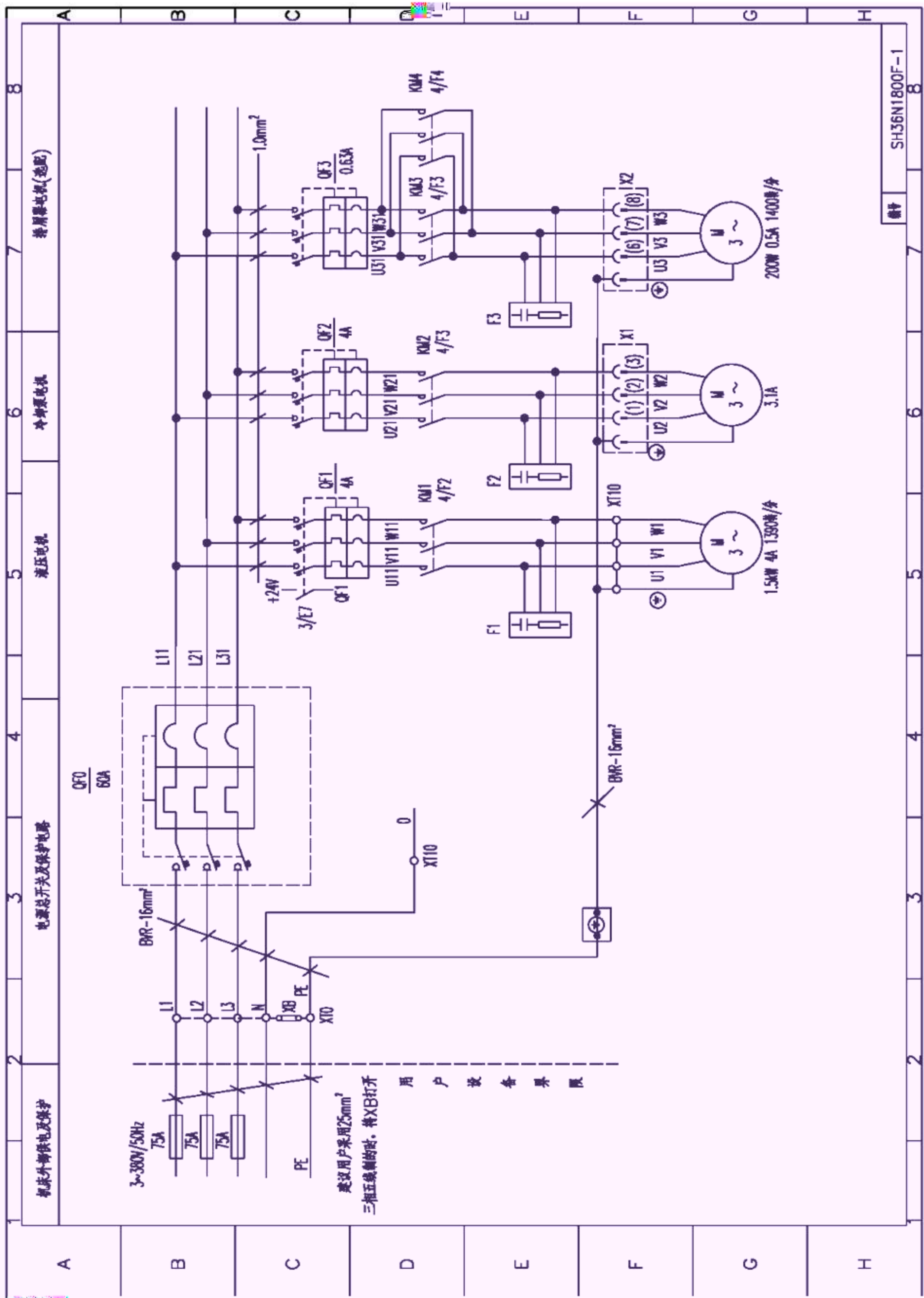

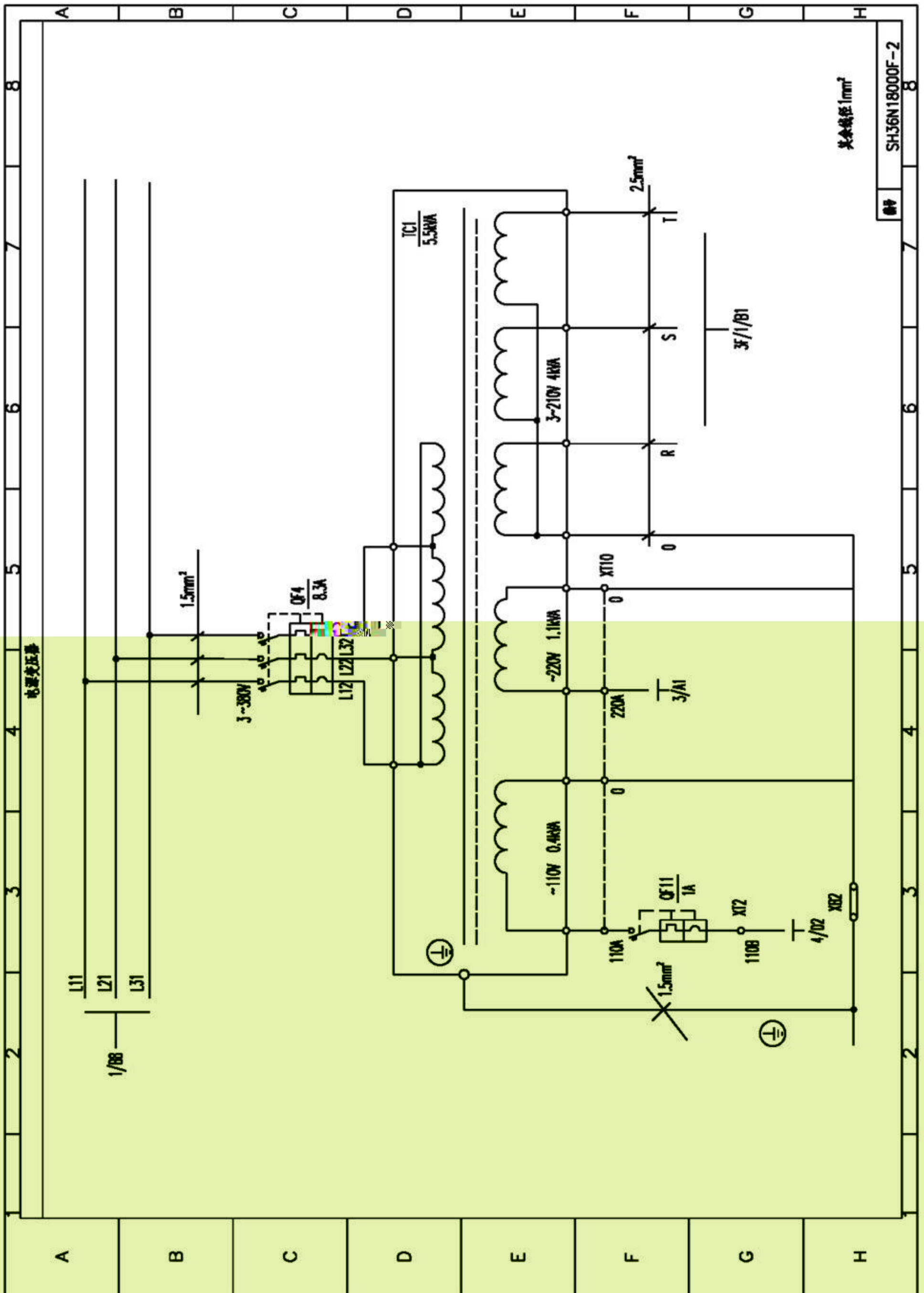

其余导线 1mm<sup>2</sup>  
 SH36N18000F-2

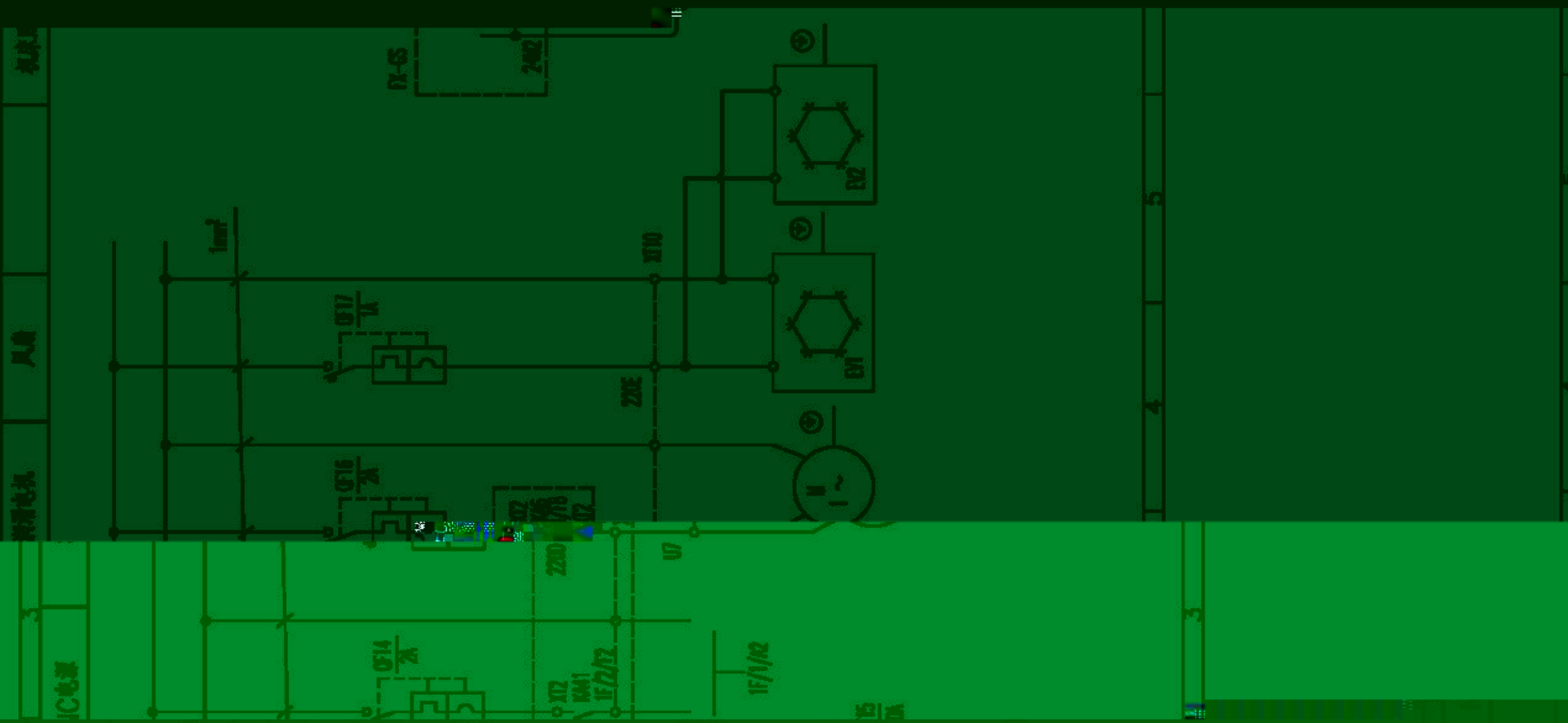
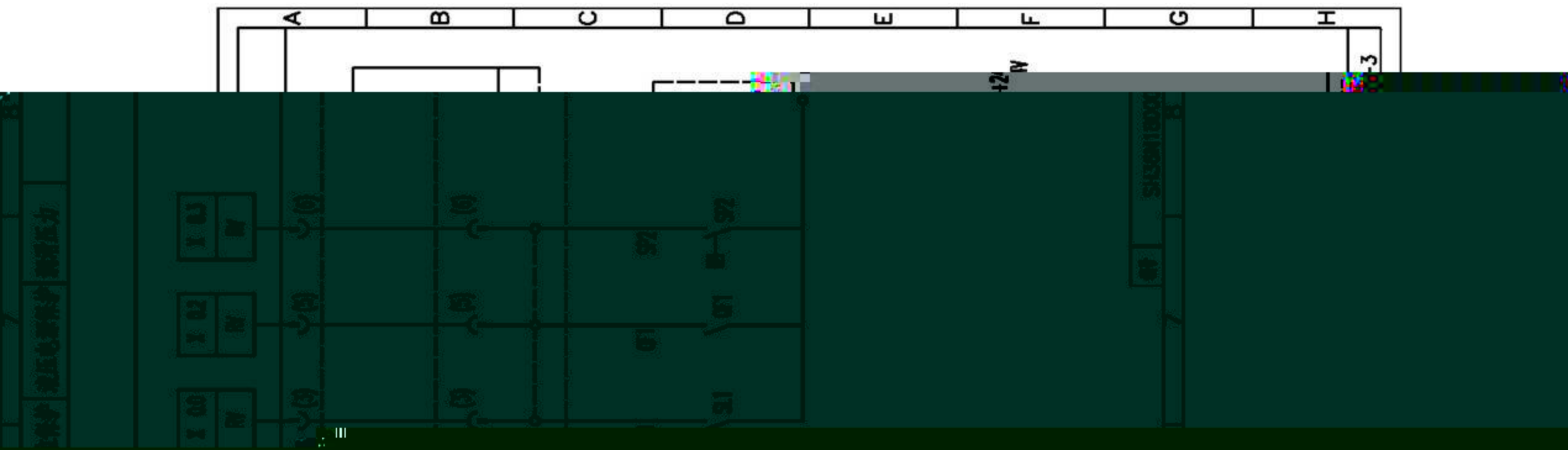

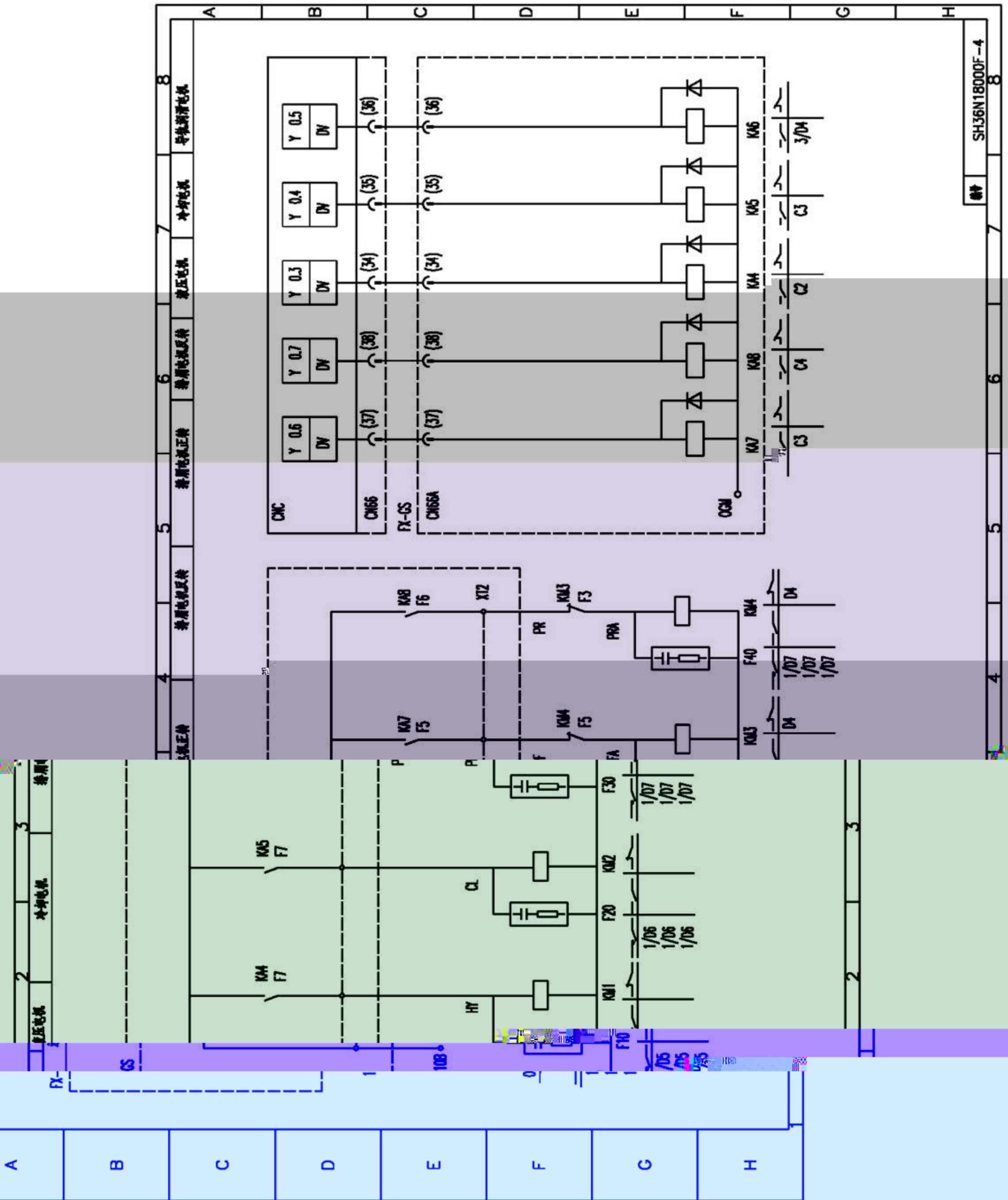



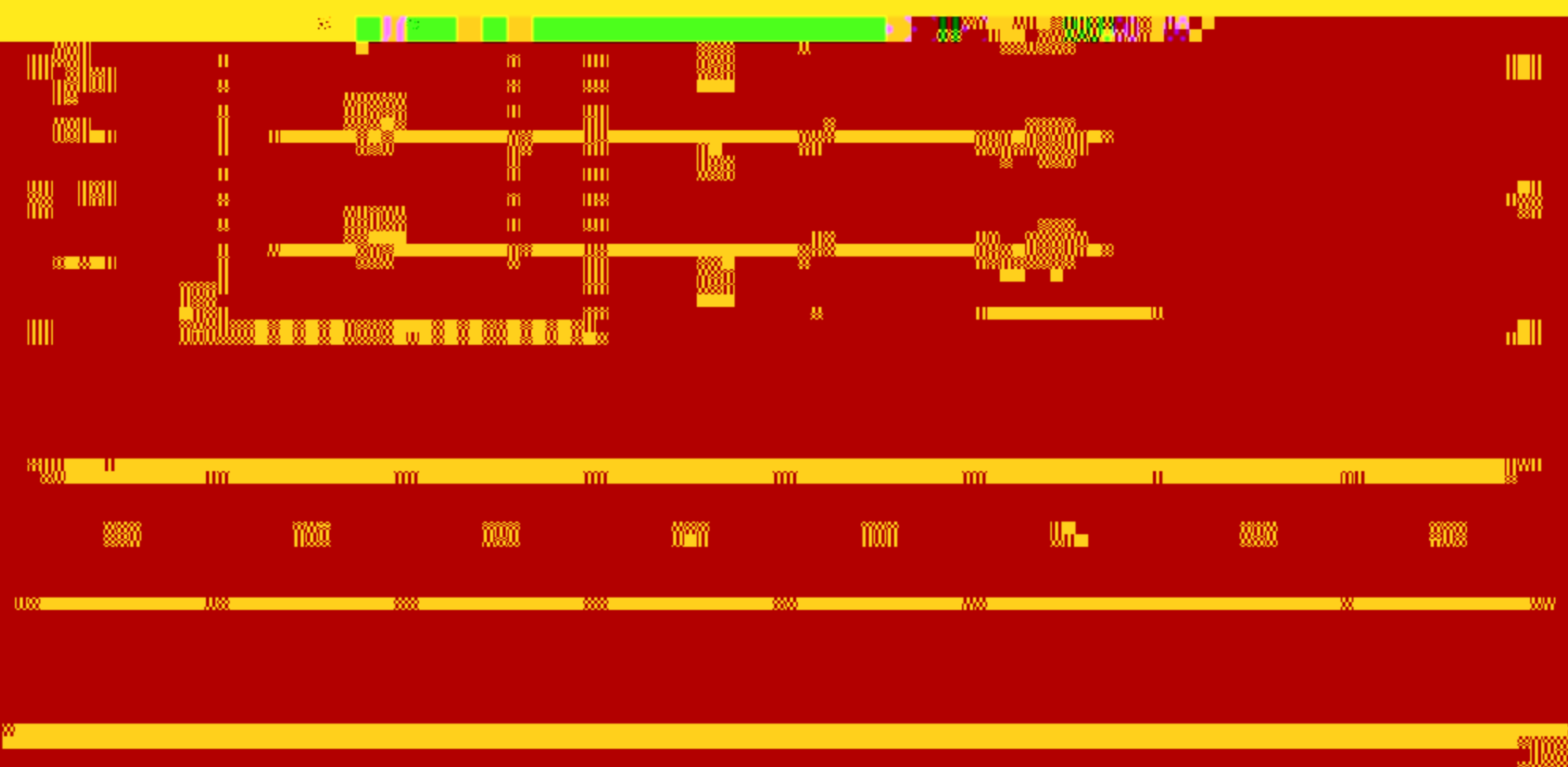
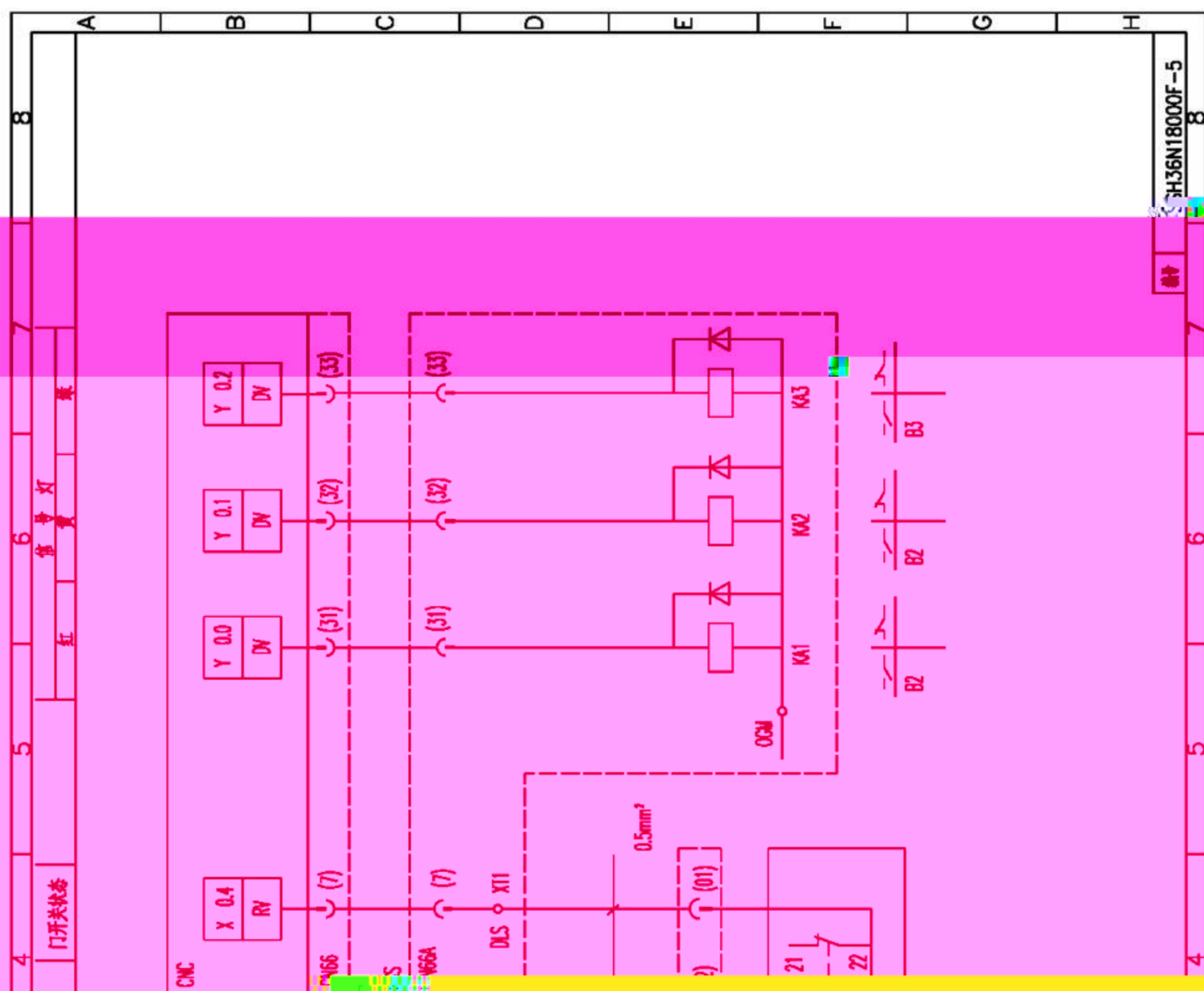

## 2 CNC 电路

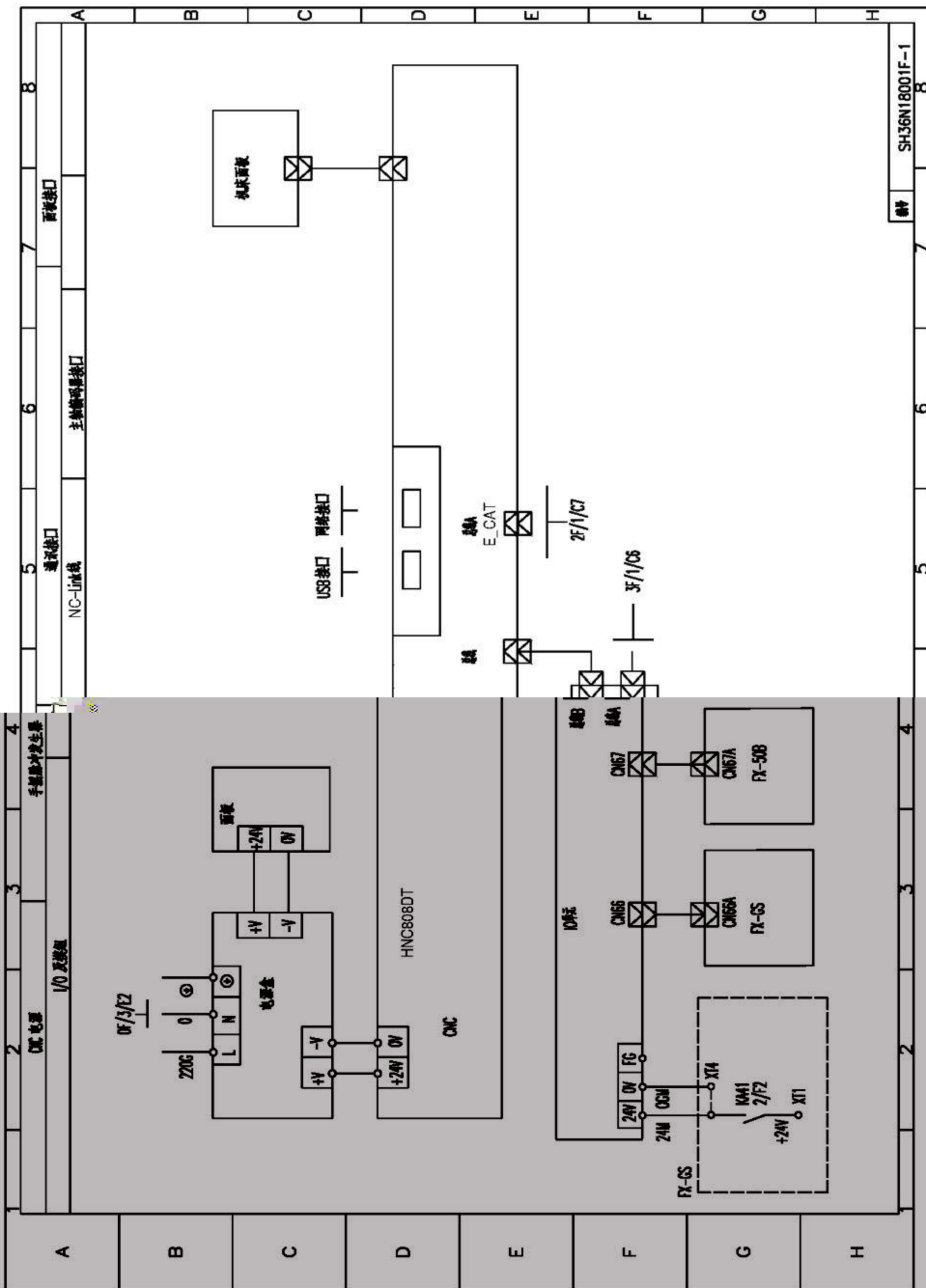



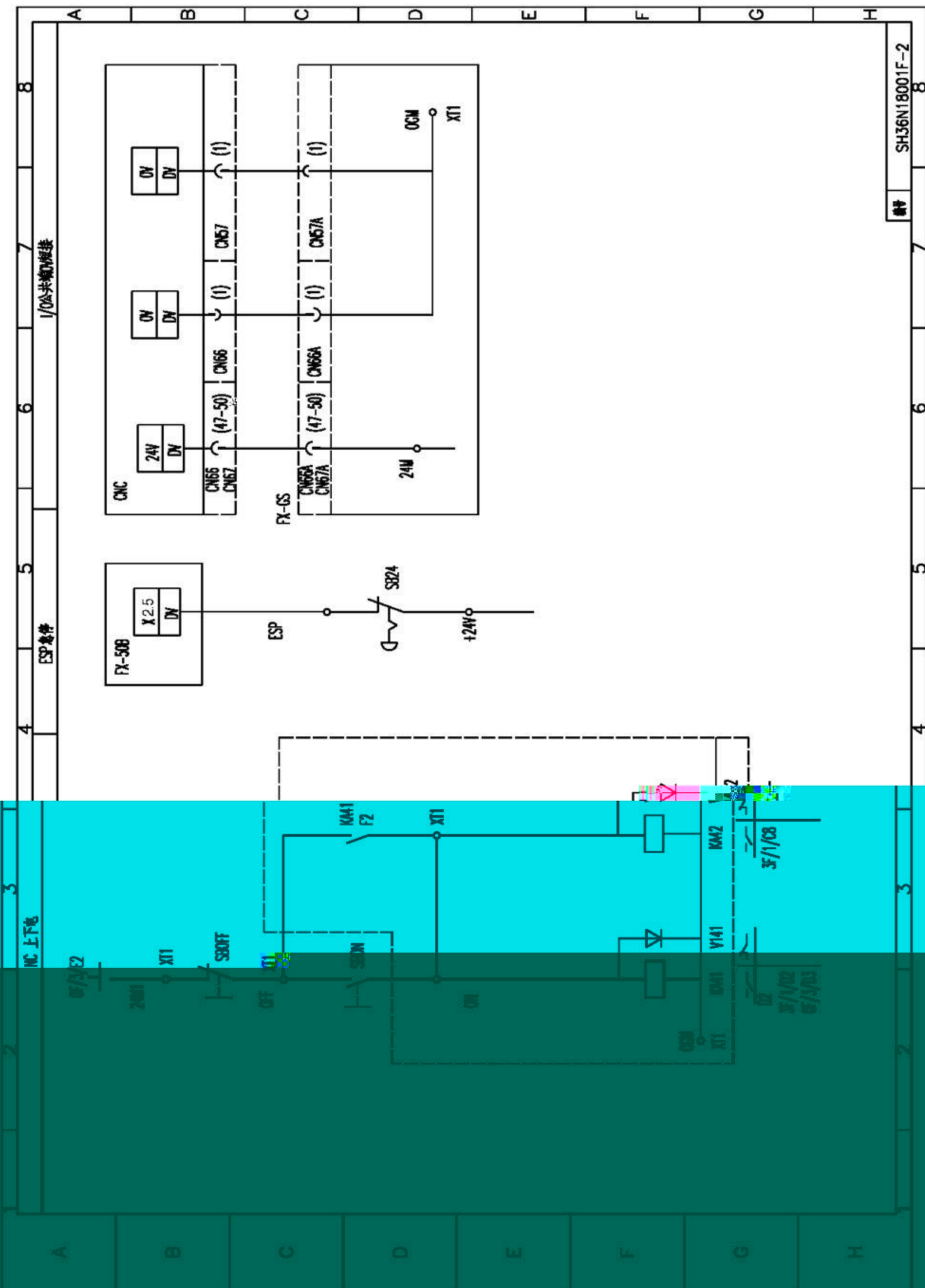

### 3 主轴电路

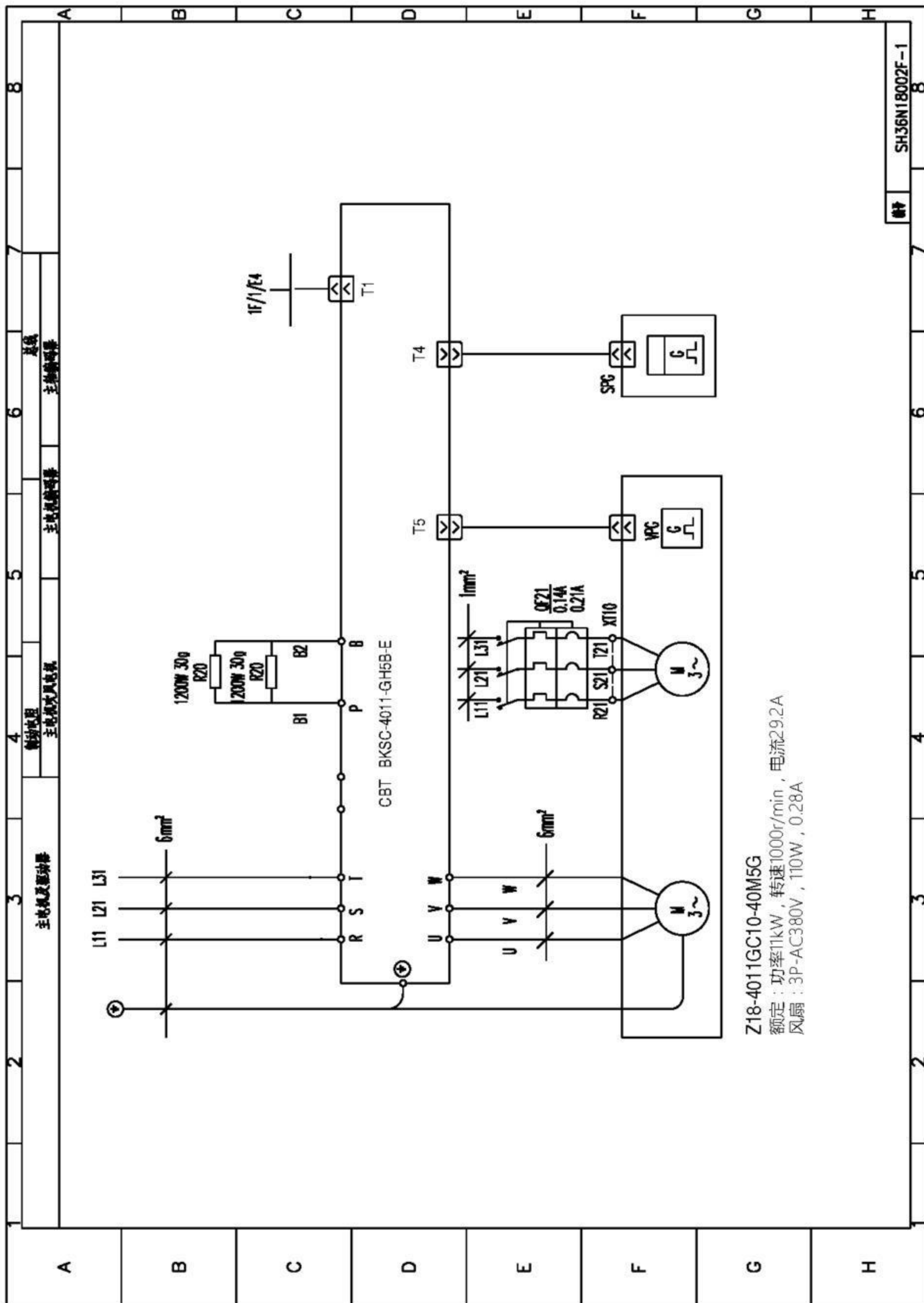

Z18-4011GC10-40M5G  
 额定：功率11kW，转速1000r/min，电流29.2A  
 风扇：3P-AC380V，110W，0.28A

### 4 伺服轴电路

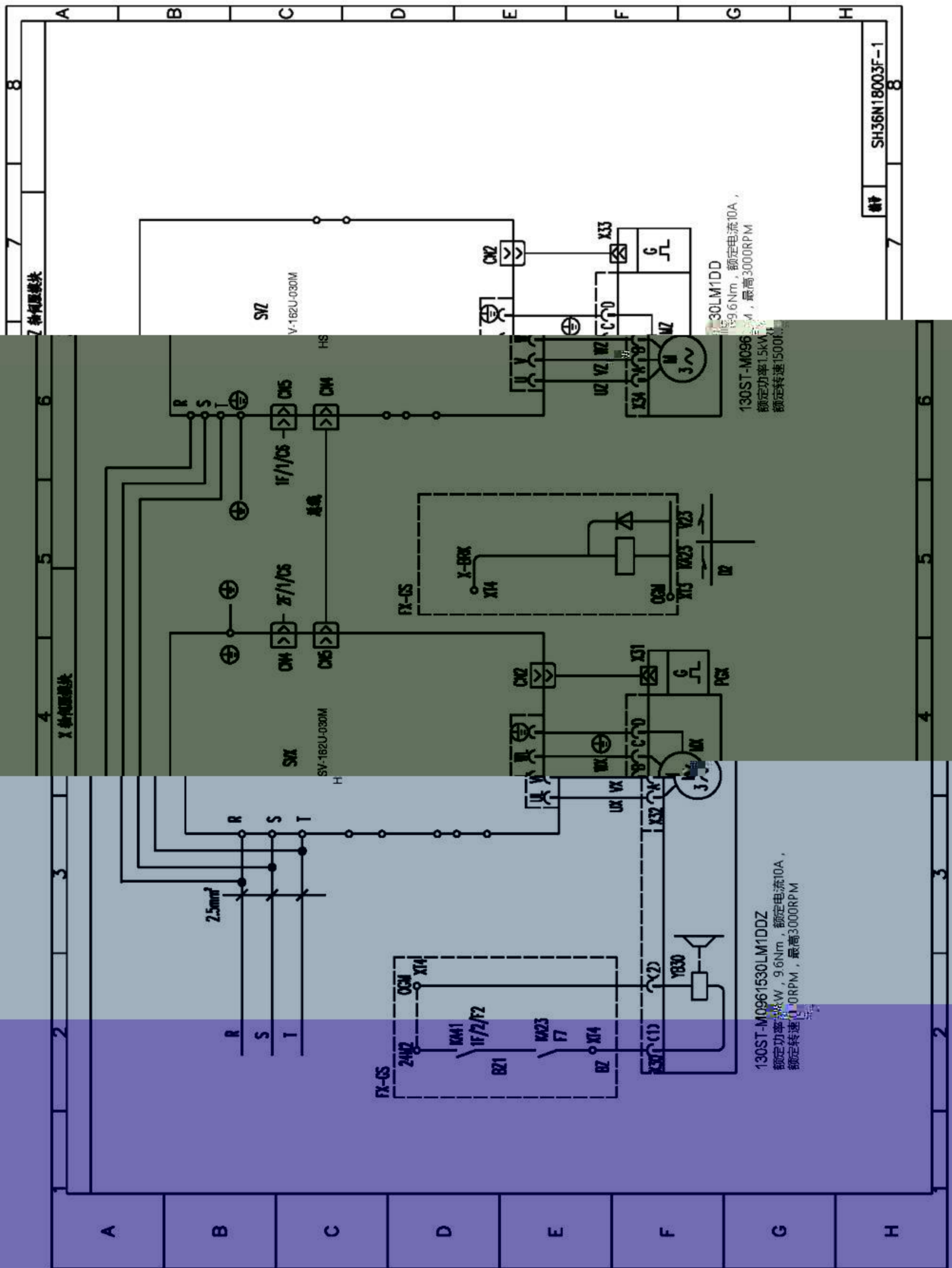

### 5 刀架电路

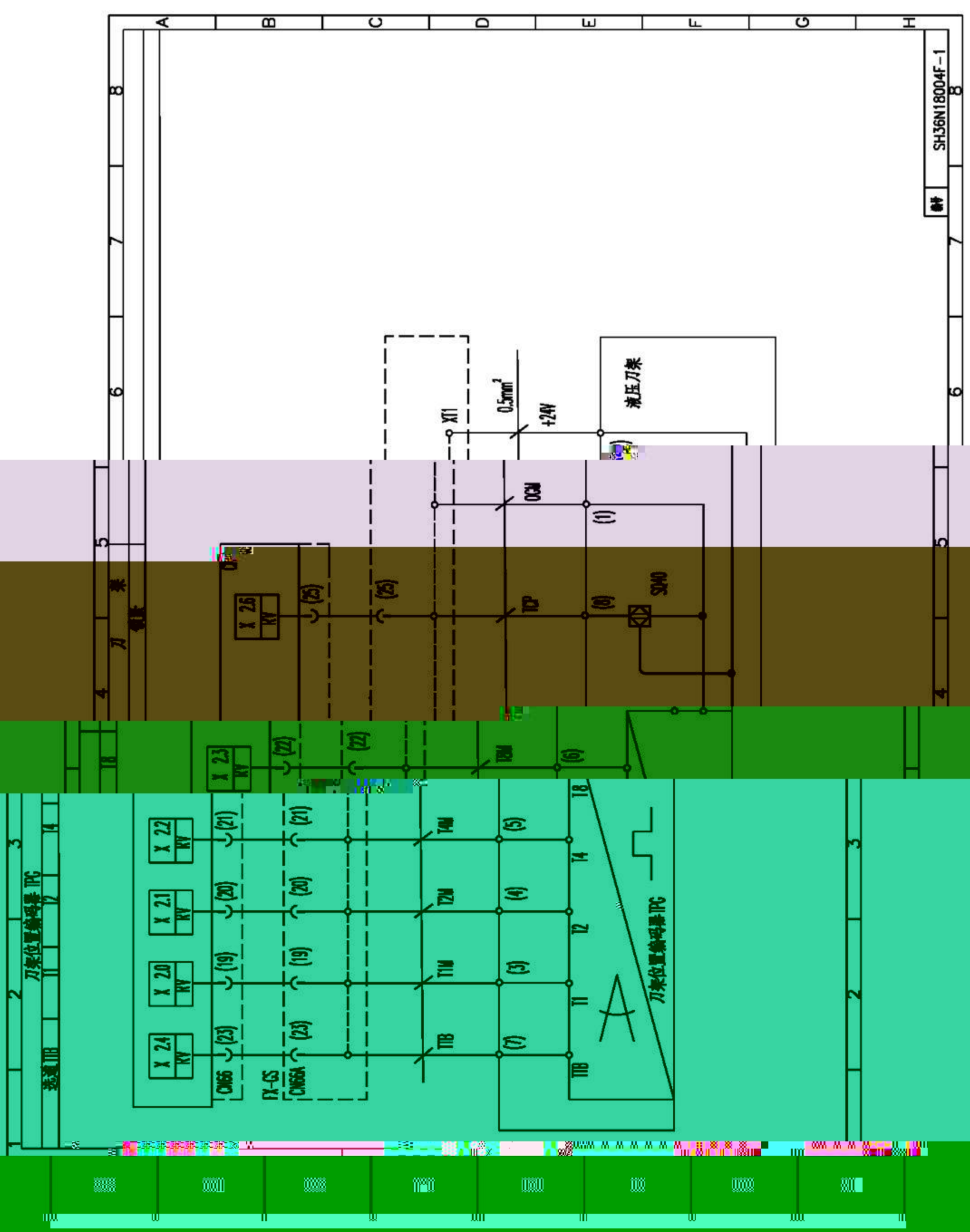

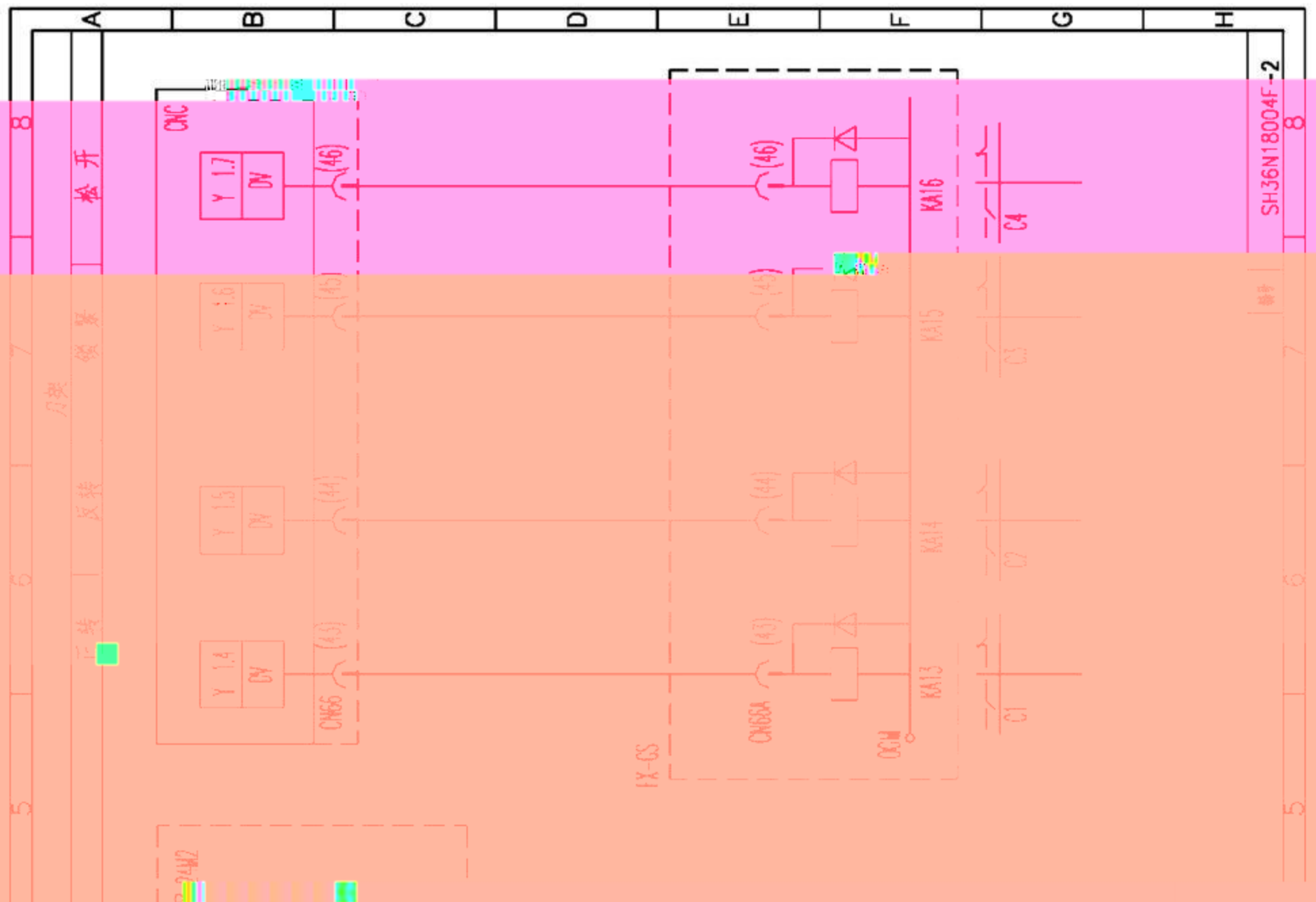

### 6 卡盘电路

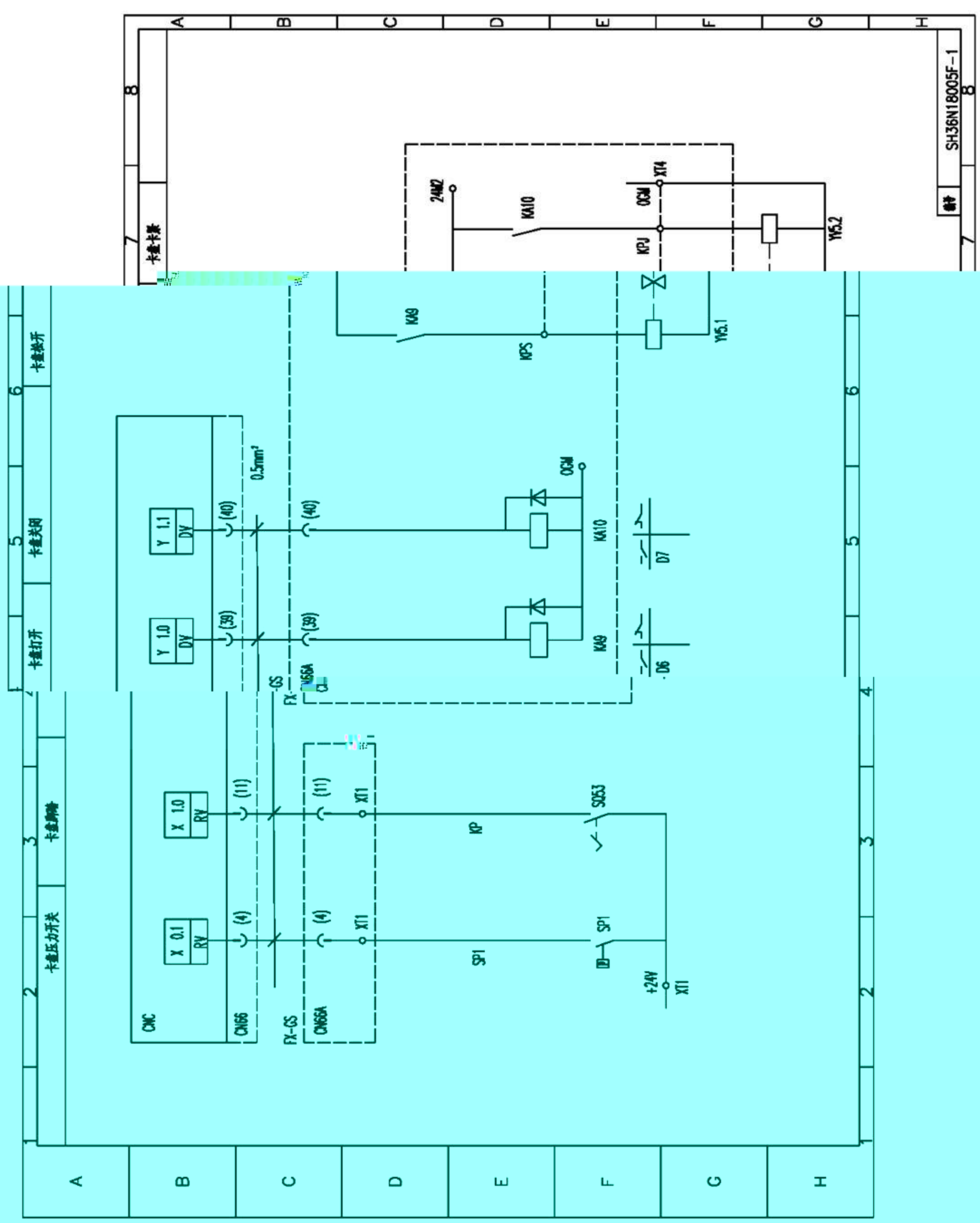



## 7 台尾电路

### 7.1 台尾套管

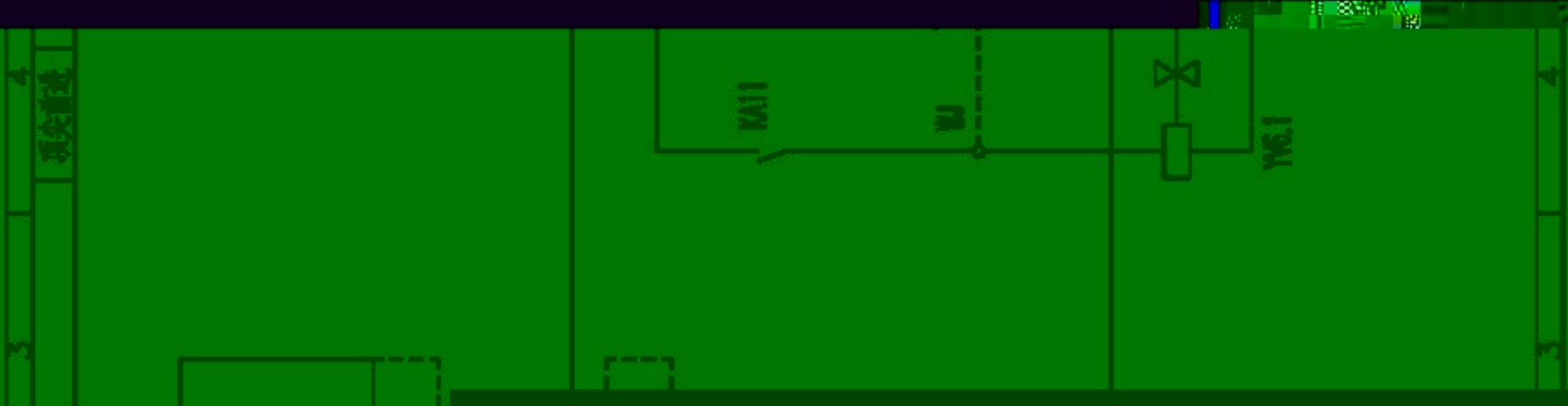
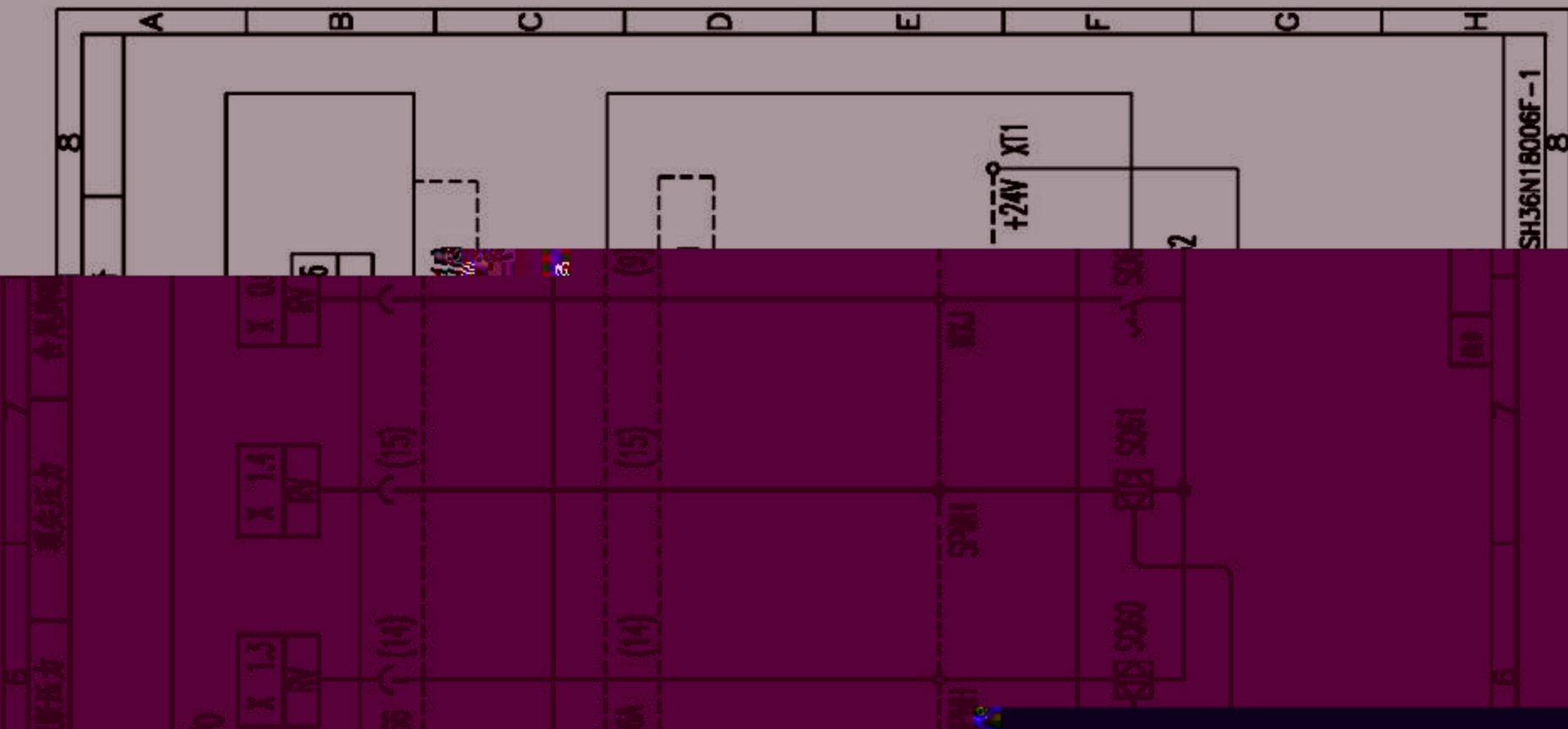

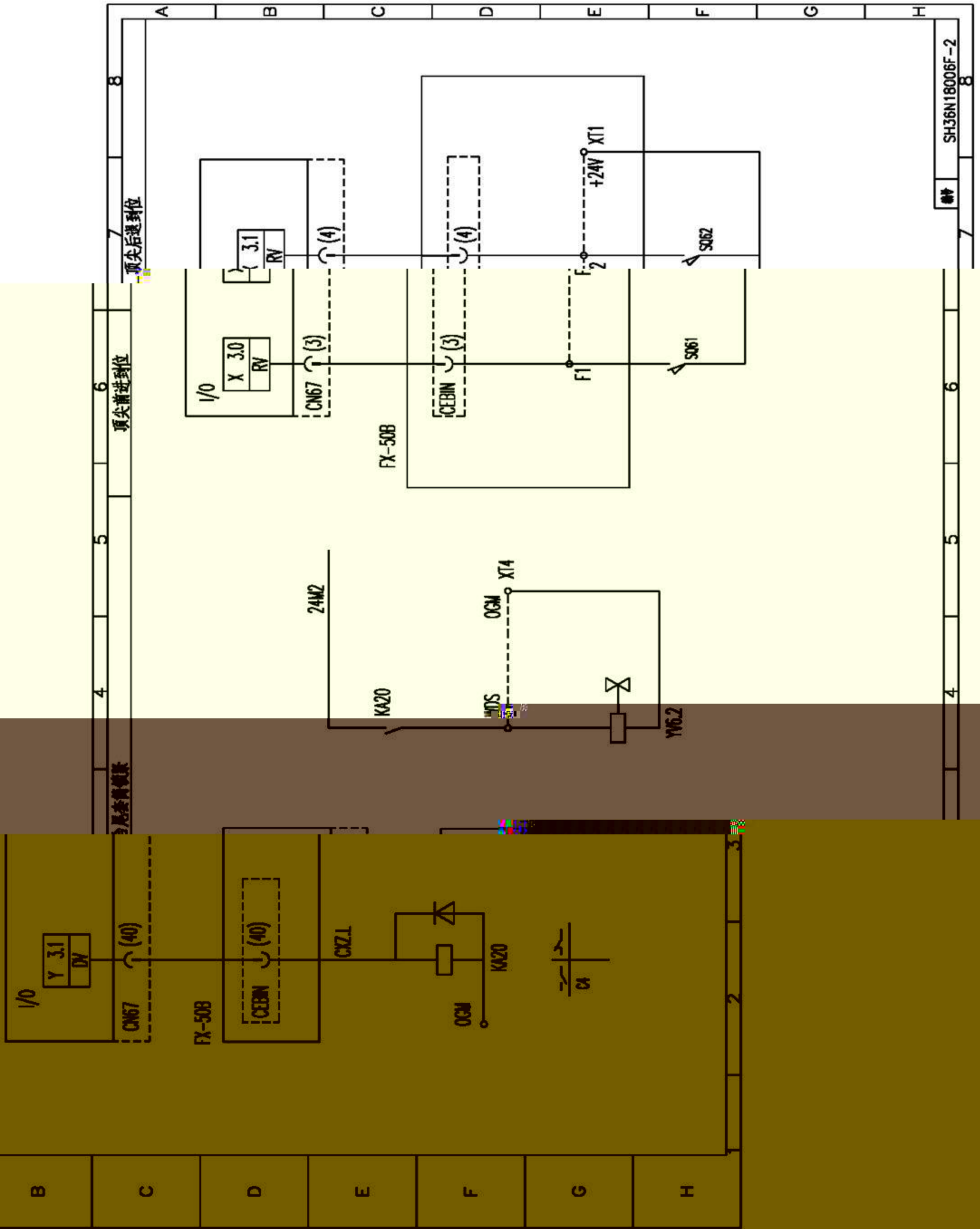

7.2 台尾体(选配)

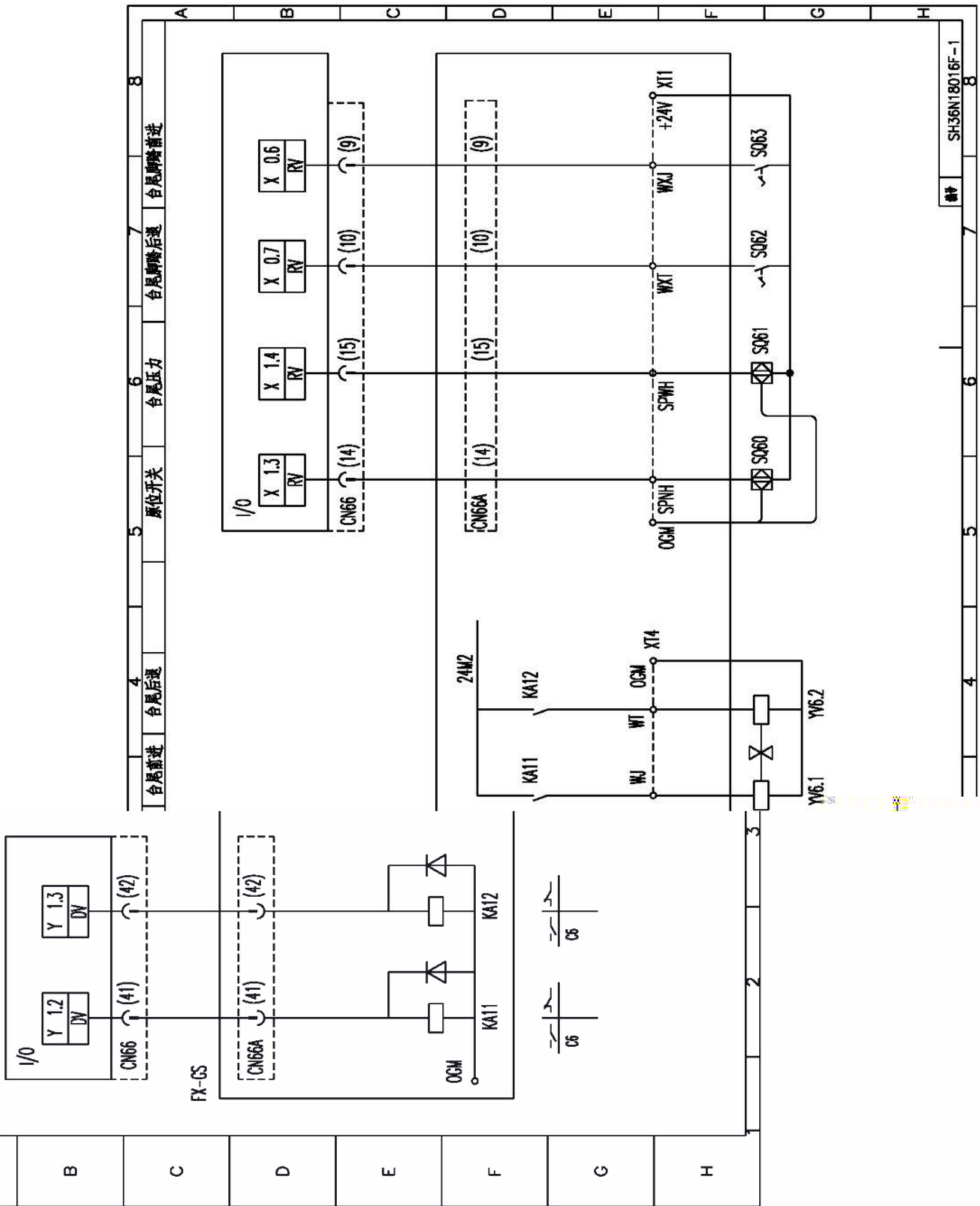



# 备注